

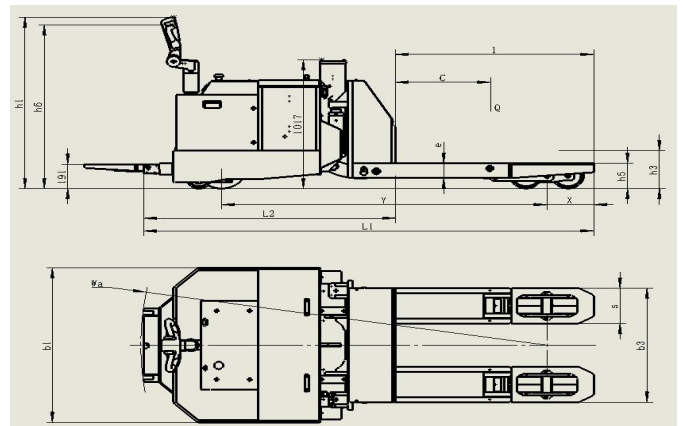

Zowell XP100 & 120 quotation sheet & technical data

				XP100	XP120
Specification	1	Model		XP100	XP120
	2	Power supply		Electric	Electric
	3	Drive type		Standing	Standing
	4	Load capacity	Q kg	10000	12000
	5	Load center	C mm	850	850
	6	Load distance, Center of drive axle to fork back	X mm	295	295
	7	Wheelbase	Y mm	2258	2258
Weight	1	Self weight (with battery)	kg	2410	2510
Wheels	1	Tyres		Polurethane	Polurethane
	2	Drive wheel size	mm	Φ310×140	Φ310×140
	3	Load wheel size	mm	Φ200×60	Φ200×60
	4	Balance wheel size	mm	Φ150×60	Φ150×60
	5	Wheels qty (Front/Rear) (x=drive wheel)		1x-4/8	1x-4/8
	6	Tread, Front	mm	830	830
	7	Tread, Rear	mm	470	470
Basic data	1	Overall height	h1mm	1355	1355
	2	Lift height	h3mm	300	300
	3	Fork height (lowest)	h5mm	200	200
	4	Height of tiller in drive position (Max/Min)	h6mm	1290/1092	1290/1092
	5	Overall length (platform folded)	L1mm	2840.5	2840.5
	6	Length to face of fork	L2mm	1590.5	1590.5
	7	Overall width	b1mm	1220	1220
	8	Fork size	s/e/lmm	278/118/1650	278/118/1650
	9	Fork width	b3 mm	900	900
	10	Ground clearance (Unloaded)	M mm	80	80
	11	Turning radius	Wa mm	2965	2965
Performance	1	Drive speed Loaded/Unloaded	km/h	3.6/4	3/3.5
	2	Lift speed Loaded/Unloaded	mm/s	28/40	28/40
	3	Lower speed Loaded/unloaded	mm/s	45/40	45/40
	4	Max Gradeability Loaded/unloaded	%	2.5/8	2.5/6
	5	Service brake		Electromagnetic brake	Electromagnetic brake
Motor	1	Drive motor	kw	4.5	4.5
	2	Lift motor	kw	6.3	6.3
	3	Lithium Battery voltage and capacity	V/Ah	48/300	48/300
	4	Battery weight	Kg	430	485
Other	1	Control unit type		Mosfet control	Mosfet control
	2	Noise	dB(A)	<70	<70



Drive	1	Drive motor: Tongda 1R142003	4.5KW 2950RPM Maximum rotational speed 4750RPM
	2	Steer motor: Tongda SA074330101	AC0.7KW 2280RPM Maximum rotational speed 4000RPM
	3	Gear box: ZF GK20	Maximum wheel load 2000Kg, maximum turning radius 168mm, maximum wheel torque 980NM, travel transmission ratio 19.8
Controller	1	Drive: CURTIS 1234	
	2	Steer: CURTIS 1222	
Battery	1	48V-300Ah	Lithium
Hydraulic system	1	Pump motor: Baoluo XQD-6.3	DC 6.3KW 2000RPM Maximum rotational speed 3200RPM Excitation mode: compound excitation
		Later changed to: Wannan XQD-5.5	DC 5.5KW 1500RPM Maximum rotational speed 3600RPM Excitation mode: series excitation
	2	Gear pump: Shimadzu DSG05C12F9H9-R216C	Rated pressure: 20.6MPa Maximum pressure: 22.6MPa Minimum rotational speed: 500r/min Maximum rotational speed: 3000r/min Theoretical flowing capacity: 12ml/r

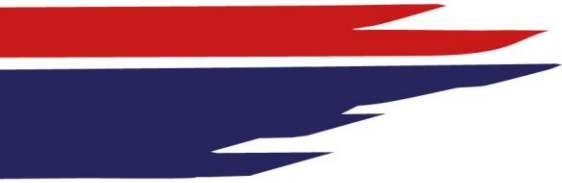

Handling Equipment UK Ltd
Coronation Works, Providence Street
Lye, Stourbridge
DY9 8HN

T: 01384 423330

E: info@HandlingEquipment.co.uk

W: www.handlingequipmentonline.com



NATIONAL DISTRIBUTOR OF



FS 816242

