

LI-ION
TECHNOLOGY



ECOWARRIOR



ECO X5 SERIES

**LI-ION COUNTERBALANCE FORKLIFT TRUCK
2500-3800KG**

**NATIONAL
DISTRIBUTOR**
**LOCAL
SERVICE**

- ▶ Modular battery design for flexible battery capacity adjustment
- ▶ Battery configurations available, even two modules for heavy-duty power
- ▶ Lithium technology for opportunity charging and minimal maintenance
- ▶ High travel and lift speeds, as well as strong gradeability for maximum efficiency
- ▶ 150mm ground clearance and large tyres to tackle all surfaces
- ▶ Improved key components, including the mast, lights, seat, display and controls

THE MOST COST-EFFECTIVE PRODUCT ON THE MARKET!

FOR FURTHER
INFORMATION CALL

01384 423 330

www.eco-warrior.uk

FEATURES



ECOWARRIOR

► FLEXIBILITY

The X5 series features a modular Li-ion battery design and offers one standard 280Ah lithium battery module. The truck can accommodate up to two battery modules and, through pairwise combination, boost to 560Ah capacity. This allows for battery capacity adjustment to meet different application requirements.



INDIVIDUAL BATTERY FOR STANDARD USAGE

DOUBLE BATTERIES FOR EXTRA LONG ENDURANCE OR PEAK SEASON

► OPTIMISATION

A modular battery design offers both a medium and high battery capacity in one truck, making it suitable for a range of demands. This versatile solution helps businesses to reduce their fixed assets, manage stock effectively and – for dealers – to respond quickly to user needs. Simply install the second battery for heavy-duty tasks, and you're ready to go!



► ENDURANCE

Your daily usage needs may change over the years or have seasonal peaks. A modular battery system makes it easy to retrofit an additional battery, providing additional power exactly when you need it.



► LONGEVITY

Double batteries, double guarantee. Rest easy knowing that in the unlikely event of one battery failing, another is on hand to pick up the slack.

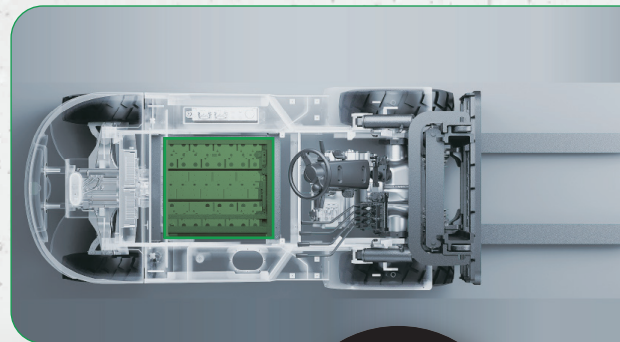

**NATIONAL
DISTRIBUTOR**

**LOCAL
SERVICE**

THE MOST COST-EFFECTIVE PRODUCT ON THE MARKET!

FOR FURTHER
INFORMATION CALL

01384 423 330

www.eco-warrior.uk

FEATURES



ECOWARRIOR

▶ PRODUCTIVITY

The X5 series demonstrates high performance levels, enhancing overall efficiency.

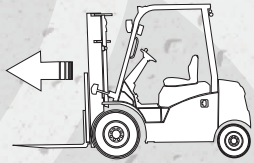

16/17km/h

Travel speed (laden/unladen)

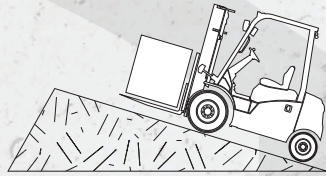

20/25%

Max. gradeability (laden/unladen)

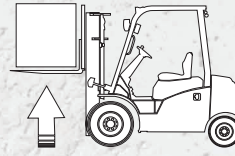

0.45/0.55m/s

Lifting speed (laden/unladen)

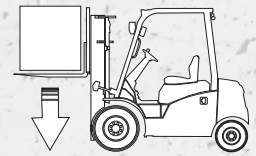

0.5/0.44m/s

Lowering speed (laden/unladen)

▶ COST-EFFECTIVENESS

The X5 series is designed around innovative Li-ion technology and meets sustainability requirements. It is supported by opportunity charging, meaning minimal downtime and requires far less maintenance than a traditional machine.

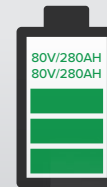

▶ ALL-TERRAIN

This model provides a higher ground clearance of 150mm and large tyres, protecting the forklift from the elements on rough terrain. It is a powerful workhorse to handle loads on tougher sites.



▶ COMFORT

This truck is equipped with improved components, including the new triplex mast with high visibility, a new seat with an armrest and new LED front lights. There's also a wider brake pedal installed, and a large, clear LED display.



**NATIONAL
DISTRIBUTOR**

**LOCAL
SERVICE**

THE MOST COST-EFFECTIVE PRODUCT ON THE MARKET!

FOR FURTHER
INFORMATION CALL

01384 423 330

www.eco-warrior.uk

ECO252X5, 302X5, 352X5, 382X5

LI-ION COUNTERBALANCE FORKLIFT TRUCK
2500-3800KG



ECOWARRIOR

Specification	1.1	Manufacturer			ECOWARRIOR	ECOWARRIOR	ECOWARRIOR	ECOWARRIOR	
	1.2	Model designation			ECO252X	ECO302X5	ECO352X5	ECO382X5	
	1.3	Drive unit			Electric	Electric	Electric	Electric	
	1.4	Operator type			Seated	Seated	Seated	Seated	
	1.5	Load capacity	Q	Kg	2500	3000	3500	3800	
	1.6	Load center distance	c	mm	500	500	500	500	
	1.8	Load distance centre of drive axle to fork	x	mm	495	481	486	501	
	1.9	Wheelbase	y	mm	1685	1760	1760	1760	
	Weight	2.1	Service weight			Kg	3835	4820	5020
2.2		Axle loading, laden front/rear			Kg	5679/656	6510/1310	7290/1230	7910/1240
2.3		Axle loading, unladen front/rear			Kg	1711/2124	1835/2985	1810/3210	1950/3400
Tyres/Chassis	3.1	Tyre type				Pneumatic	Pneumatic	Pneumatic	Pneumatic
	3.2	Tyre size, front		mm	7.00-12-12PR	28X9-15-14PR	28X9-15-14PR	250-15	
	3.3	Tyre size, rear		mm	18X7-8-14PR	6.50-10-10PR	6.50-10-10PR	6.50-10	
	3.5	Wheels, number front/rear (x=drive wheels)		mm	2 x / 2	2 x / 2	2 x / 2	2 x / 2	
	3.6	Tread width, front	b ₁₀	mm	975	1010	1010	1010	
	3.7	Tread width, rear	b ₁₁	mm	955	980	980	980	
Dimensions	4.1	Tilt of mast/fork carriage forward/backward	α/β	°	6/10	6/10	6/10	6/10	
	4.2	Retracted mast height	h1	mm	2090	2065	2065	2065	
	4.3	Free lift	h2	mm	195	135	135	135	
	4.4	Lift height	h3	mm	3000	3000	3000	3000	
	4.5	Height, mast extended	h4	mm	4065	4130	4130	4130	
	4.7	Height of overhead guard (cabin)	h6	mm	2165	2160	2160	2160	
	4.8	Seat height/standing height	h7	mm	1095	1095	1095	1095	
	4.12	Tow coupling height	h ₁₀	mm	315	280	280	280	
	4.19	Overall length	l1	mm	3590	3819	3824	3865	
	4.20	Length to face of forks	l ₂	mm	2520	2749	2754	2795	
	4.21	Overall width	b ₁ / b ₂	mm	1154	1230	1230	1250	
	4.22	Fork dimensions	s*e'l	mm	40×122×1070	45×122×1070	50×122×1070	50×122×1070	
	4.23	A,B Fork carriage class/type A, B			2A	3A	3A	3A	
	4.24	Fork carriage width	b ₃	mm	1040	1100	1100	1100	
	4.31	Ground clearance, laden, below mast	m ₁	mm	100	120	120	120	
	4.32	Ground clearance, center of wheelbase	m ₂	mm	150	150	150	150	
	4.34.1	Aisle width for pallets 1000 × 1200 crossways	Ast	mm	3965	4179	4184	4225	
4.34.2	Aisle width for pallets 800 × 1200 lengthways	Ast	mm	4165	4379	4384	4425		
4.35	Turning radius	Wa	mm	2270	2498	2498	2524		
Performance data	5.1	Travel speed, laden/unladen		km/h	16/17	16/17	16/17	15/16	
	5.2	Lifting speed, laden/unladen		m/s	0.38/0.45	0.45/0.55	0.44/0.55	0.43/0.52	
	5.3	Lowering speed, laden/unladen		m/s	0.45/0.52	0.5/0.44	0.5/0.44	0.5/0.4	
	5.8	Max. gradeability, laden/unladen		%	17/25	20/25	18/25	16/20	
	5.10	Service brake			Hydraulic	Hydraulic	Hydraulic	Hydraulic	
	5.11	Parking brake			Mechanical	Mechanical	Mechanical	Mechanical	
Electric engine	6.1	Drive motor rating S2 60 min		kW	16	16	16	16	
	6.2	Lift motor rating at S3 15%		kW	24	24	24	24	
	6.4	Battery voltage/nominal capacity		V/Ah	80V280AH	80V280AH	80V280AH	80V280AH	
Drive/lift mechanism	8.1	Type of drive unit			AC	AC	AC	AC	
Add'l data	10.5	Steering type			Hydraulic	Hydraulic	Hydraulic	Hydraulic	
	10.7	Sound pressure level at the driver's ear		dB (A)	< 74	< 74	< 74	< 74	

THE MOST COST-EFFECTIVE PRODUCT ON THE MARKET!

FOR FURTHER
INFORMATION CALL

01384 423 330

www.eco-warrior.uk

NATIONAL
DISTRIBUTOR

LOCAL
SERVICE

DIMENSIONS



ECOWARRIOR

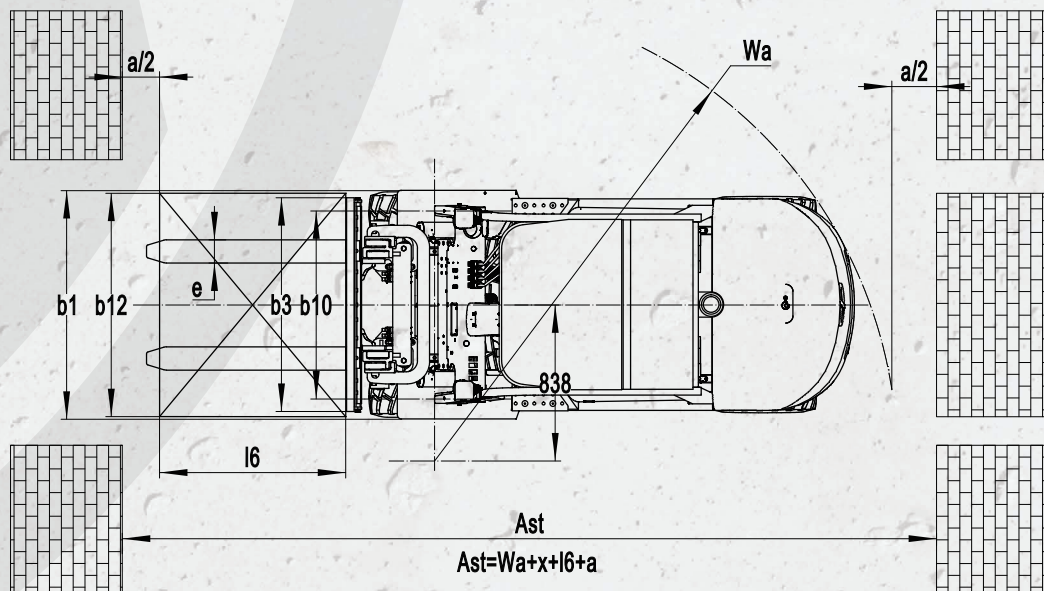
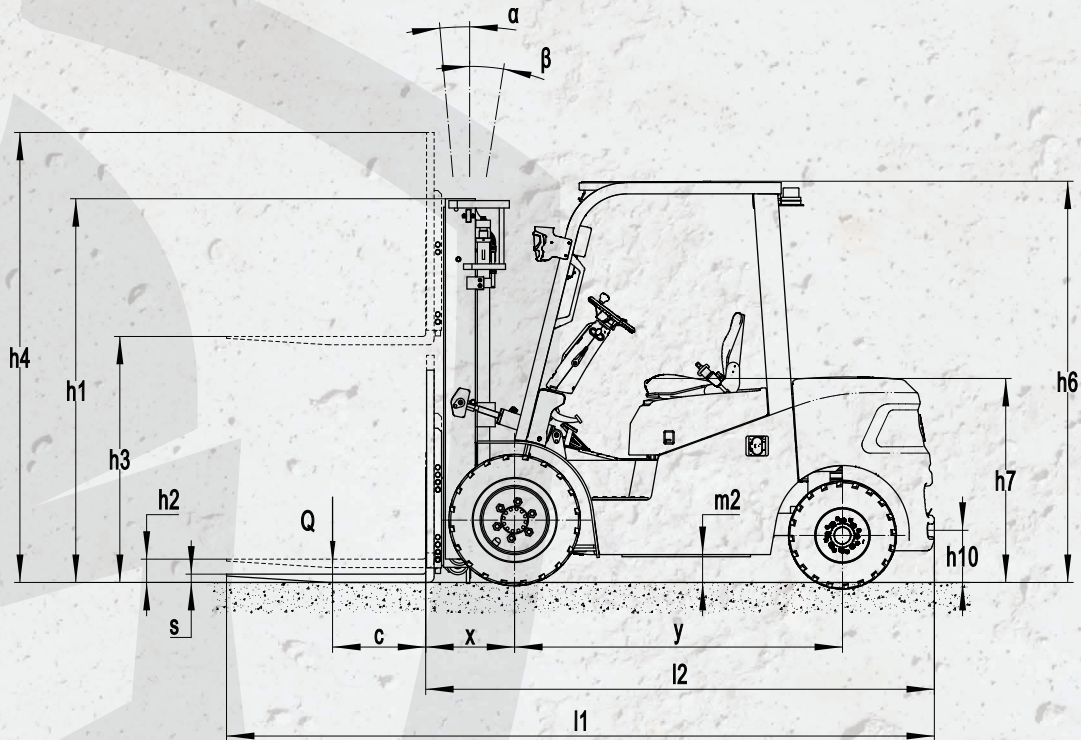

THE MOST COST-EFFECTIVE PRODUCT ON THE MARKET!

FOR FURTHER
INFORMATION CALL

01384 423 330



www.eco-warrior.uk

MAST OPTIONS



ECOWARRIOR

ECO252X5

RATED CAPACITIES AND LOAD CENTRES GRAPH

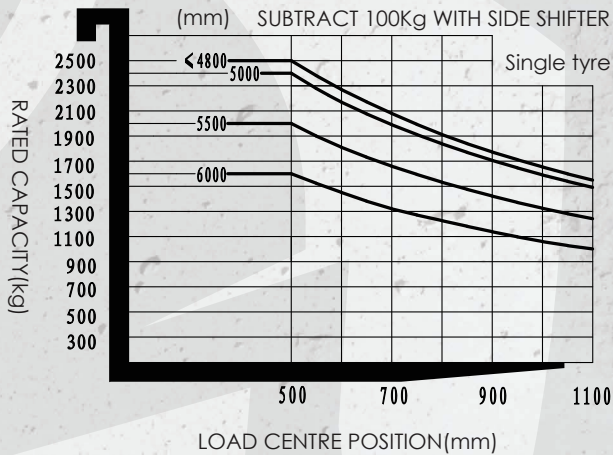

ECO302X5

RATED CAPACITIES AND LOAD CENTRES GRAPH

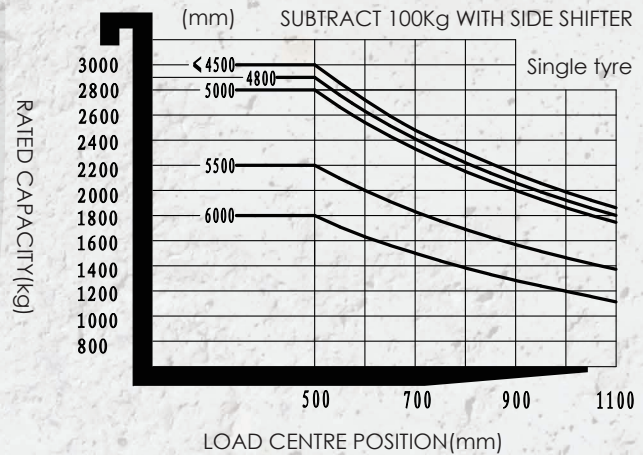

ECO352X5

RATED CAPACITIES AND LOAD CENTRES GRAPH

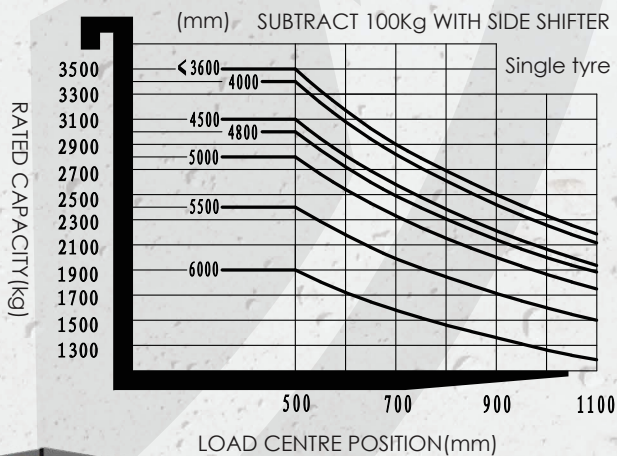

ECO382X5

RATED CAPACITIES AND LOAD CENTRES GRAPH

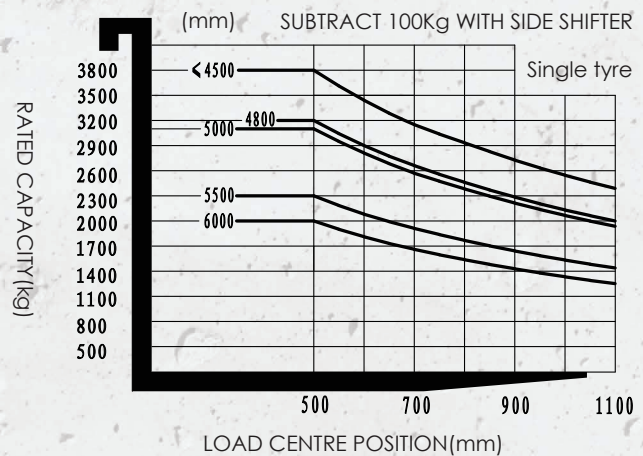

THE MOST COST-EFFECTIVE PRODUCT ON THE MARKET!

FOR FURTHER INFORMATION CALL

01384 423 330

www.eco-warrior.uk



MAST OPTIONS



ECOWARRIOR

ECO252X5

Type	Max. Fork Height	Overall Height			Free Lift	
		Lowered	Extended		Without Backrest	With Backrest
			Without Backrest	With Backrest		
	mm	mm	mm	mm	mm	mm
Duplex Standard Mast	3000	2090	3595	4060	195	195
	3300	2240	3895	4360	195	195
	3500	2340	4095	4560	195	195
	3600	2390	4195	4660	195	195
	4000	2640	4595	5060	195	195
	4500	2890	5095	5560	195	195
Duplex Full Free Mast	3000	2035	3765	4100	1345	1010
	3300	2185	4065	4400	1495	1160
	3600	2335	4365	4700	1645	1310
Triplex Full Free Mast	4300	2080	5040	5355	1370	1055
	4500	2160	5280	5595	1450	1135
	4800	2265	5580	5895	1555	1240
	5000	2350	5730	6045	1640	1325
	5500	2600	6230	6545	1890	1575
	6000	2850	6730	7045	2140	1825

ECO302X5

Type	Max. Fork Height	Overall Height			Free Lift	
		Lowered	Extended		Without Backrest	With Backrest
			Without Backrest	With Backrest		
	mm	mm	mm	mm	mm	mm
Duplex Standard Mast	3000	2065	3665	4130	135	135
	3300	2215	3965	4430	135	135
	3500	2315	4165	4630	135	135
	3600	2365	4265	4730	135	135
	4000	2615	4665	5130	135	135
	4500	2865	5165	5630	135	135
Duplex Full Free Mast	3000	2045	3715	4175	1410	950
	3300	2195	4015	4475	1560	1100
	3600	2345	4315	4775	1710	1250
Triplex Full Free Mast	4300	2080	5030	5435	1390	985
	4500	2160	5270	5675	1470	1065
	4800	2265	5570	5975	1575	1170
	5000	2350	5720	6125	1660	1255
	5500	2600	6220	6625	1910	1505
	6000	2850	6720	7125	2160	1755



THE MOST COST-EFFECTIVE PRODUCT ON THE MARKET!

FOR FURTHER INFORMATION CALL

01384 423 330

www.eco-warrior.uk

MAST OPTIONS



ECOWARRIOR

ECO352X5

Type	Max. Fork Height	Overall Height			Free Lift	
		Lowered	Extended		Without Backrest	With Backrest
			Without Backrest	With Backrest		
mm	mm	mm	mm	mm	mm	
Duplex Standard Mast	3000	2065	3665	4130	135	135
	3300	2215	3965	4430	135	135
	3500	2315	4165	4630	135	135
	3600	2365	4265	4730	135	135
	4000	2615	4665	5130	135	135
	4500	2865	5165	5630	135	135
Duplex Full Free Mast	3000	2045	3715	4175	1410	950
	3300	2195	4015	4475	1560	1100
	3600	2345	4315	4775	1710	1250
Triplex Full Free Mast	4300	2080	5030	5435	1390	985
	4500	2160	5270	5675	1470	1065
	4800	2265	5570	5975	1575	1170
	5000	2350	5720	6125	1660	1255
	5500	2600	6220	6625	1910	1505
	6000	2850	6720	7125	2160	1755

ECO382X5

Type	Max. Fork Height	Overall Height			Free Lift	
		Lowered	Extended		Without Backrest	With Backrest
			Without Backrest	With Backrest		
mm	mm	mm	mm	mm	mm	
Duplex Standard Mast	3000	2065	3665	4130	135	135
	3300	2215	3965	4430	135	135
	3500	2315	4165	4630	135	135
	3600	2365	4265	4730	135	135
	4000	2615	4665	5130	135	135
	4500	2865	5165	5630	135	135
Duplex Full Free Mast	3000	2045	3715	4175	1410	950
	3300	2195	4015	4475	1560	1100
	3600	2345	4315	4775	1710	1250
Triplex Full Free Mast	4300	2080	5030	5435	1390	985
	4500	2160	5270	5675	1470	1065
	4800	2265	5570	5975	1575	1170
	5000	2350	5720	6125	1660	1255
	5500	2600	6220	6625	1910	1505
	6000	2850	6720	7125	2160	1755

THE MOST COST-EFFECTIVE PRODUCT ON THE MARKET!

FOR FURTHER INFORMATION CALL

01384 423 330

www.eco-warrior.uk





ECOWARRIOR

OPTIONAL EXTRAS

OPTIONAL ITEMS	ECO252X5	ECO302X5	ECO352X5	ECO382X5
Fork dimension	<ul style="list-style-type: none"> ● 122*40*920 ● 122*40*1070 ■ 122*40*1150 ■ 122*40*1220 ■ 122*40*1370 ■ 122*40*1500 ■ 122*40*1600 ■ 122*40*1700 ■ 122*40*1820 ■ 122*40*1900 ■ 122*40*2000 ■ 122*40*2200 	<ul style="list-style-type: none"> ● 122*40*1070 ■ 122*40*1150 ■ 122*40*12200 ■ 122*40*1370 ■ 122*40*1520 ■ 122*40*1600 ■ 122*40*1700 ■ 122*40*1820 ■ 122*40*2000 ■ 122*40*2200 ■ 122*40*2400 	<ul style="list-style-type: none"> ● 122*50*1070 ■ 122*50*1150 ■ 122*50*12200 ■ 122*50*1370 ■ 122*50*1520 ■ 122*50*1600 ■ 122*50*1700 ■ 122*50*1820 ■ 122*50*2000 ■ 122*50*2200 ■ 122*50*2400 	<ul style="list-style-type: none"> ● 122*50*1070 ■ 122*50*1150 ■ 122*50*12200 ■ 122*50*1370 ■ 122*50*1520 ■ 122*50*1600 ■ 122*50*1700 ■ 122*50*1820 ■ 122*50*2000 ■ 122*50*2200 ■ 122*50*2400
Front wheel material	<ul style="list-style-type: none"> ■ Pneumatic ■ Normal solid ■ Traceless solid 	<ul style="list-style-type: none"> ■ Pneumatic ■ Normal solid ■ Traceless solid 	<ul style="list-style-type: none"> ■ Pneumatic ■ Normal solid ■ Traceless solid 	<ul style="list-style-type: none"> ■ Normal solid ■ Traceless solid
Rear wheel material	<ul style="list-style-type: none"> ■ Pneumatic ■ Normal solid ■ Traceless solid 	<ul style="list-style-type: none"> ■ Pneumatic ■ Normal solid ■ Traceless solid 	<ul style="list-style-type: none"> ■ Pneumatic ■ Normal solid ■ Traceless solid 	<ul style="list-style-type: none"> ■ Normal solid ■ Traceless solid
Battery capacity	<ul style="list-style-type: none"> ● 80V280AH ■ 80V560AH 	<ul style="list-style-type: none"> ● 80V280AH ■ 80V560AH 	<ul style="list-style-type: none"> ● 80V280AH ■ 80V560AH 	<ul style="list-style-type: none"> ● 80V280AH ■ 80V560AH
Charger	<ul style="list-style-type: none"> ■ 80V35A (integrated) ■ 80V60A (integrated) ■ 80V60A ■ 80V100A ■ 80V150A ■ 80V200A (560AH) 	<ul style="list-style-type: none"> ■ 80V35A (integrated) ■ 80V60A (integrated) ■ 80V60A ■ 80V100A ■ 80V150A ■ 80V200A (560AH) 	<ul style="list-style-type: none"> ■ 80V35A (integrated) ■ 80V60A (integrated) ■ 80V60A ■ 80V100A ■ 80V150A ■ 80V200A (560AH) 	<ul style="list-style-type: none"> ■ 80V35A (integrated) ■ 80V60A (integrated) ■ 80V60A ■ 80V100A ■ 80V150A ■ 80V200A (560AH)
Battery indicator	<ul style="list-style-type: none"> ● With time (Bluetooth) without PSE ■ With time (Bluetooth) with PSE 	<ul style="list-style-type: none"> ■ With time (Bluetooth) with PSE 	<ul style="list-style-type: none"> ■ With time (Bluetooth) with PSE 	<ul style="list-style-type: none"> ■ With time (Bluetooth) with PSE
Seat type	<ul style="list-style-type: none"> ■ Comfortable + safety belt switch ■ Seat with armrest with safety belt switch ■ Suspension + safety belt switch 	<ul style="list-style-type: none"> ■ Comfortable + safety belt switch ■ Seat with armrest with safety belt switch ■ Suspension + safety belt switch 	<ul style="list-style-type: none"> ■ Comfortable + safety belt switch ■ Seat with armrest with safety belt switch ■ Suspension + safety belt switch 	<ul style="list-style-type: none"> ■ Comfortable + safety belt switch ■ Seat with armrest with safety belt switch ■ Suspension + safety belt switch
Attachments	<ul style="list-style-type: none"> ■ Built-in sideshifter ■ External shifter ■ Fork positioner with sideshift ■ Clamp 	<ul style="list-style-type: none"> ■ Built-in sideshifter ■ External shifter ■ Fork positioner with sideshift ■ Clamp 	<ul style="list-style-type: none"> ■ Built-in sideshifter ■ External shifter ■ Fork positioner with sideshift ■ Clamp 	<ul style="list-style-type: none"> ■ Built-in sideshifter ■ External shifter ■ Fork positioner with sideshift ■ Clamp
Clamp interlock	<ul style="list-style-type: none"> ● No ■ Clamp interlock 	<ul style="list-style-type: none"> ● No ■ Clamp interlock 	<ul style="list-style-type: none"> ● No ■ Clamp interlock 	<ul style="list-style-type: none"> ● No ■ Clamp interlock
Traction pin	<ul style="list-style-type: none"> ● Yes and not customised 	<ul style="list-style-type: none"> ● Yes and not customised 	<ul style="list-style-type: none"> ● Yes and not customised 	<ul style="list-style-type: none"> ● Yes and not customised
Anti-static chain	<ul style="list-style-type: none"> ● Yes and not customised 	<ul style="list-style-type: none"> ● Yes and not customised 	<ul style="list-style-type: none"> ● Yes and not customised 	<ul style="list-style-type: none"> ● Yes and not customised
Front lamp	<ul style="list-style-type: none"> ● LED 	<ul style="list-style-type: none"> ● LED 	<ul style="list-style-type: none"> ● LED 	<ul style="list-style-type: none"> ● LED
Rear lamp	<ul style="list-style-type: none"> ● No ■ LED 	<ul style="list-style-type: none"> ● No ■ LED 	<ul style="list-style-type: none"> ● No ■ LED 	<ul style="list-style-type: none"> ● No ■ LED
Warning lamp	<ul style="list-style-type: none"> ● Yes and not customised 	<ul style="list-style-type: none"> ● Yes and not customised 	<ul style="list-style-type: none"> ● Yes and not customised 	<ul style="list-style-type: none"> ● Yes and not customised
Turn signal light	<ul style="list-style-type: none"> ● LED 	<ul style="list-style-type: none"> ● LED 	<ul style="list-style-type: none"> ● LED 	<ul style="list-style-type: none"> ● LED
Blue lamp	<ul style="list-style-type: none"> ● No ■ Rear ■ Front and rear 	<ul style="list-style-type: none"> ● No ■ Rear ■ Front and rear 	<ul style="list-style-type: none"> ● No ■ Rear ■ Front and rear 	<ul style="list-style-type: none"> ● No ■ Rear ■ Front and rear
Area warning lamp	<ul style="list-style-type: none"> ● No ■ Both side ■ Both side and rear 	<ul style="list-style-type: none"> ● No ■ Both side ■ Both side and rear 	<ul style="list-style-type: none"> ● No ■ Both side ■ Both side and rear 	<ul style="list-style-type: none"> ● No ■ Both side ■ Both side and rear
Rearview mirror	<ul style="list-style-type: none"> ● One in front ■ two on sides ■ two on side and one in front 	<ul style="list-style-type: none"> ● One in front ■ two on sides ■ two on side and one in front 	<ul style="list-style-type: none"> ● One in front ■ two on sides ■ two on side and one in front 	<ul style="list-style-type: none"> ● One in front ■ two on sides ■ two on side and one in front
Buzzer	<ul style="list-style-type: none"> ● Yes and not customised 	<ul style="list-style-type: none"> ● Yes and not customised 	<ul style="list-style-type: none"> ● Yes and not customised 	<ul style="list-style-type: none"> ● Yes and not customised
OPS system	<ul style="list-style-type: none"> ● Yes and not customised 	<ul style="list-style-type: none"> ● Yes and not customised 	<ul style="list-style-type: none"> ● Yes and not customised 	<ul style="list-style-type: none"> ● Yes and not customised
USB interface	<ul style="list-style-type: none"> ● USB with A and C type 	<ul style="list-style-type: none"> ● USB with A and C type 	<ul style="list-style-type: none"> ● USB with A and C type 	<ul style="list-style-type: none"> ● USB with A and C type
Telematics	<ul style="list-style-type: none"> ● Yes and not customised ■ No 	<ul style="list-style-type: none"> ● Yes and not customised ■ No 	<ul style="list-style-type: none"> ● Yes and not customised ■ No 	<ul style="list-style-type: none"> ● Yes and not customised ■ No
Turn speed control	<ul style="list-style-type: none"> ● No ■ Yes and not customised 	<ul style="list-style-type: none"> ● No 	<ul style="list-style-type: none"> ● No 	<ul style="list-style-type: none"> ● No
Heating system during lithium battery charging	<ul style="list-style-type: none"> ● No ■ Yes and not customised 	<ul style="list-style-type: none"> ● No ■ Yes and not customised 	<ul style="list-style-type: none"> ● No ■ Yes and not customised 	<ul style="list-style-type: none"> ● No ■ Yes and not customised
Operator identification device	<ul style="list-style-type: none"> ● No ■ Card reader 	<ul style="list-style-type: none"> ● No ■ Card reader 	<ul style="list-style-type: none"> ● No ■ Card reader 	<ul style="list-style-type: none"> ● No ■ Card reader
Lifting electronic limit	<ul style="list-style-type: none"> ● No ■ Yes and not customised 	<ul style="list-style-type: none"> ● No ■ Yes and not customised 	<ul style="list-style-type: none"> ● Yes and not customised ■ No 	<ul style="list-style-type: none"> ● Yes and not customised ■ No
Hydraulic control	<ul style="list-style-type: none"> ● Mechanical lever ■ Joystick ■ Fingertip 	<ul style="list-style-type: none"> ● Mechanical lever ■ Joystick ■ Fingertip 	<ul style="list-style-type: none"> ● Mechanical lever ■ Joystick ■ Fingertip 	<ul style="list-style-type: none"> ● Mechanical lever ■ Joystick ■ Fingertip
Rear armrest horn	<ul style="list-style-type: none"> ● Yes and not customised 	<ul style="list-style-type: none"> ● Yes and not customised 	<ul style="list-style-type: none"> ● Yes and not customised 	<ul style="list-style-type: none"> ● Yes and not customised
Cabin	<ul style="list-style-type: none"> ● No ■ Basic half cabin ■ Upgrade half cabin ■ Full cabin 	<ul style="list-style-type: none"> ● No ■ Basic half cabin ■ Upgrade half cabin ■ Full cabin 	<ul style="list-style-type: none"> ● No ■ Basic half cabin ■ Upgrade half cabin ■ Full cabin 	<ul style="list-style-type: none"> ● No ■ Basic half cabin ■ Upgrade half cabin ■ Full cabin
Overhead guard	<ul style="list-style-type: none"> ● With tempered glass ■ No 	<ul style="list-style-type: none"> ● With tempered glass ■ No 	<ul style="list-style-type: none"> ● With tempered glass ■ No 	<ul style="list-style-type: none"> ● With tempered glass ■ No
Wiper water unit	<ul style="list-style-type: none"> ● Yes only with cabin 	<ul style="list-style-type: none"> ● Yes only with cabin 	<ul style="list-style-type: none"> ● USB with A and C type 	<ul style="list-style-type: none"> ● USB with A and C type

Note ● Standard ■ Optional – NA



THE MOST COST-EFFECTIVE PRODUCT ON THE MARKET!

FOR FURTHER INFORMATION CALL

01384 423 330

www.eco-warrior.uk